



## MATLAB Simulation for Combination of Battery and Supercapacitor

A.A. Deosant, M.R. Shelke and V.G. Umale

\*Assistant Professor, P.I.G.C.E., Nagpur, (Maharashtra), India

(Corresponding author: M.R. Shelke)

(Received 27 April, 2016 Accepted 30 May, 2016)

(Published by Research Trend, Website: [www.researchtrend.net](http://www.researchtrend.net))

**ABSTRACT:** On increasing demand of electric vehicle, efficiency and performance plays a very vital role and it depends upon the energy storage system of EV. In this thesis, a new battery super capacitor hybrid energy storage system is proposed to meet the requirement. For automotive applications, the batteries are sized to ensure many constraints like start up, acceleration, braking and energy recovery. All these constraints give us a very heavy battery with very high energy compared to that required for these applications. To reduce the weight of the storage system, the battery can be associated with high power component like supercapacitor. It is one of the crucial task to improve both efficiency and performance of the electric vehicle regarding electric power density and energy capacity. Supercapacitor integrates system by means of static power converter. These systems can be completely electric or by using Fuel cell. The MATLAB simulation is performed to evaluate its performance and investigate the mitigation of battery stresses. Simulation model of hybrid energy source is presented and used to investigate the design optimization of electric vehicle on board of energy source in terms of energy efficiency and storage mass. Introduction of super capacitor reduces electric stresses, increases efficiency and enhances the overall performance.

**Keywords:** Supercapacitor, Electric vehicle, Matlab, DC/DC converter

### I. INTRODUCTION

#### A. Need of Hybridisation

Electric vehicle plays a vital role in the energy and environmental impact of a increasing transportation which offers more energy efficient and less pollution over fuel vehicle. Use of electric vehicle increasing day by day because of its benefit. The performance of EV depends upon its storage system. Up to the 2012, only battery is used as a energy storage device. Because of the peak load demand, battery fails to complete the requirement. In the battery based energy storage system (ESS'S), power density of the battery needs to be high enough to meet the peak load demand. Although batteries are available, but they are costly. It is crucial to have an additional ESS or a buffer that is much more robust in handling the surge current. In order to solve these problems, hybrid energy storage system has been proposed. The basic idea of an HESS to combine super capacitor and battery to achieve a better overall performance. Introduction of super capacitor not only reduces electric stresses but also meet vehicle power demand. It helps to achieve better performance as well as excellent control scheme during motor drive cycle. It also can reduce overall driving cost of the vehicle [1].

By adding super capacitor module with battery in EV, following are the advantages which improves the performance efficiency of the EV.

- 1) It improves vehicle acceleration.
- 2) Reduction in cost and increases life cycle
- 3) Environment eco-friendly
- 4) Improvement in driving efficiency thereby increasing in driving range [2].

This paper discusses hybrid energy storage system for EV which gives benefit discuss above.

When comparing the power characteristics of super capacitor and the battery the comparison should be made for the same charge and discharge efficiency is high and the energy lost to heat during the net cycle is relatively slow. On the other hand, the supercapacitor has high power density and battery has high energy density. Hybrid combination of battery and super capacitor gives more advantages of both high specific power and high specific energy. The main importance point in hybrid system is to balance the energy between the main source and auxiliary source. It distributes battery load with supercapacitor having high efficiency and increased battery life and its efficiency[3].

### B. Previous Works

Interesting previous works made before this report include, “Comparing DC-DC Converters for Power Management in Hybrid Electric Vehicles” (Shupbach & Balda 2003), which is a study of different topologies for supercapacitor handling. An in-depth report on control strategies and optimizations are Anderson and Groot (2003) M.Sc. thesis report “Alternative Energy Storage System for Hybrid Electric Vehicles”. The work “Comparison of Simulation Programs for Supercapacitor Modelling” by Anderson and Johansson (2008) has also been a useful resource for modelling of the super capacitor. Doerffel (2007) have studied the ageing and detrition processes of lithium-ion batteries, and how to measure the state of health [4].

### C. Purpose and Method

The purpose of study is to investigate and evaluate a combined battery and supercapacitor storage unit for hybrid vehicle applications. Important aspects are to study the effects on battery stresses which affect its lifetime when a supercapacitor is introduced, assess the

change in system efficiency and create a valid model for simulations. Furthermore, a Cuk DC/DC converter is introduced, constructed with a combined energy storage unit. The selected system will be assembled to verify simulated efficiencies. The purpose of this is to investigate and evaluate a combined battery and super capacitor storage unit for hybrid vehicle applications

## II. METHODOLOGY

### A. Block Diagram of Complete System

Block diagram consists of fuel stack cell for charging purpose, battery as a main source, DC-DC converter for maintaining the power balance of the system, super capacitor as an auxiliary source, inverter to convert DC power into AC power, and motor as a load. It is obvious that the batteries and super capacitor work as complementary to each other. So when super capacitor work in combination, uneven loading profile of the EV can also be handled very efficiently without degradation of battery.

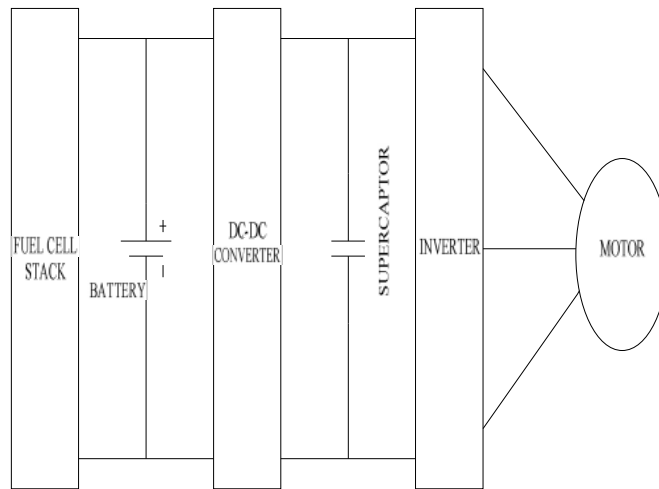

**Fig. 1.** Block diagram of hybrid energy storage system.

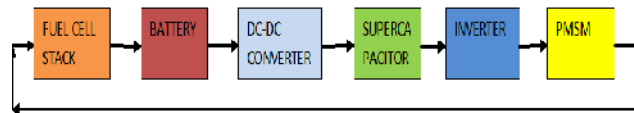

**Fig. 2.** Power flow diagram.

Here, battery is connected as a primary energy source and super capacitor as a buffer system. The main purpose to introduced hybrid energy storage system to reduce the fuel consumption of ICE. Battery is working as a main source provides supply to the whole system. Whereas, DC-DC converter is cuk type DC-DC converter maintain the power balance between battery

and super capacitor. Inverter is used to invert all the dc power into ac. Permanent magnet synchronous motor is used as a load to give efficient performance of the complete system. Fuel stack cell plays a very vital role in the hybrid energy storage system.

It works like a charger of the battery as system comes under working condition. Battery plays a role of charger to the super capacitor. Motor provides chemical energy through its speed to the fuel stack cell to keep the system in working condition. The fig. below shows the power flow in system.

**III. DESIGN/IMPLEMENTATION**

*A. Simulation Circuit and Results of Hybrid Energy Storage System with PMSM*

As block diagram of the system explained in the previous chapter, from this we implemented the system design in MATLAB. In this, as the system comes in the working condition battery starts to supply power to the

supercapacitor through DC-DC converter. To limit the charging and discharging level of battery and supercapacitor soc controller is introduced in the system with both. Further, inverter converts all the parameters in ac and fed to the permanent magnet synchronous motor and results are verified.

Hybrid energy storage system as well as manual acceleration given to the PMSM for efficient system output. Output speed of the PMSM fed to the fuel cell stack to produced chemical energy and convert it into electric energy and fed to the battery for charging battery.

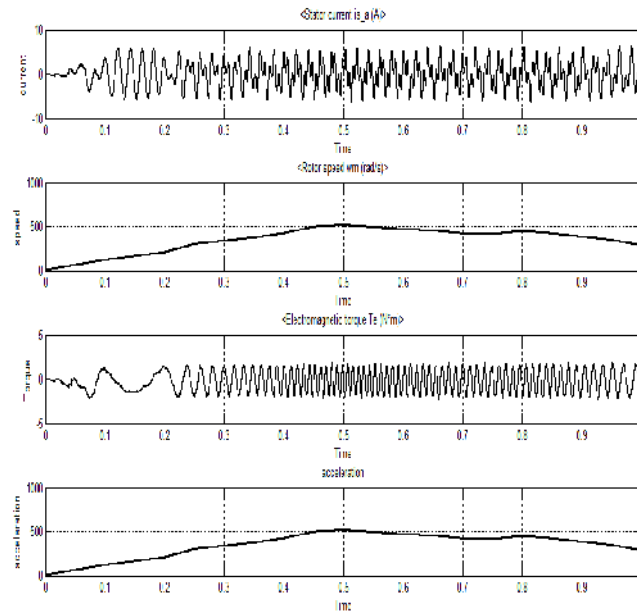

**Fig. 3.** Simulation diagram of complete hybrid energy storage system with load.

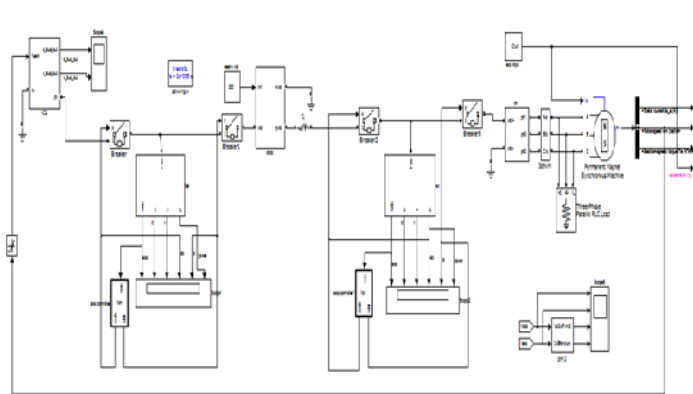

**Fig. 4.** Output of PMSM motor.

Here, 300 Vdc, 13.4 Ah Lion battery is used. We have designed Super capacitor of 1500F with 300Vdc supply. DC -DC converter is controlled by PWM converter for its switching. 300 Vdc supply given to the fuel cell stack Permanent magnet synchronous motor isof1.7Nm,300Vdc,3750rpm. simulation has been done for 1 second to observe the performance of the Hybrid energy storage system.

Below fig. shows the output result across the motor having performance of the motor with stator current, rotor speed, electromagnetic torque and acceleration respectively. Here, we can observe that speed of the motor and the acceleration given are in synchronism.

*B. Simulation circuit of Hybrid energy storage system using battery and super capacitor*

Here, the modelling of hybrid energy storage system is designed ,Battery is used as a main energy source having the 300 Vdc supply and super capacitor is as a auxiliary supply having capacity of 1500 F. Cuk type DC-DC converter is used to balance power between both the sources.

Scope1 shows the results of battery with state of charge (soc), battery voltage, battery current, connection between source and battery, connection between battery and load, power supplied by the battery.

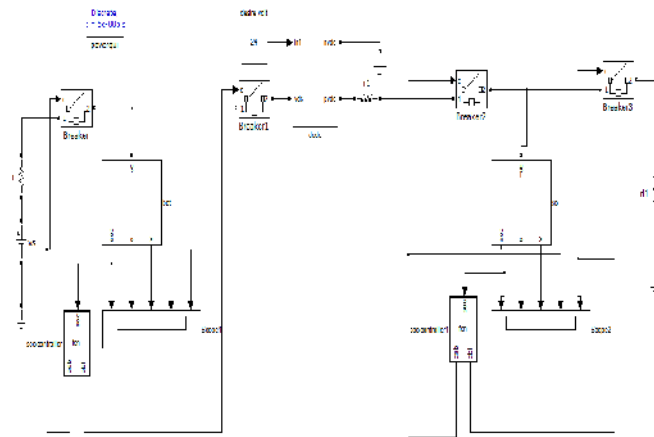

**Fig. 5.** Simulation Diagram of Hybrid Energy Storage system.

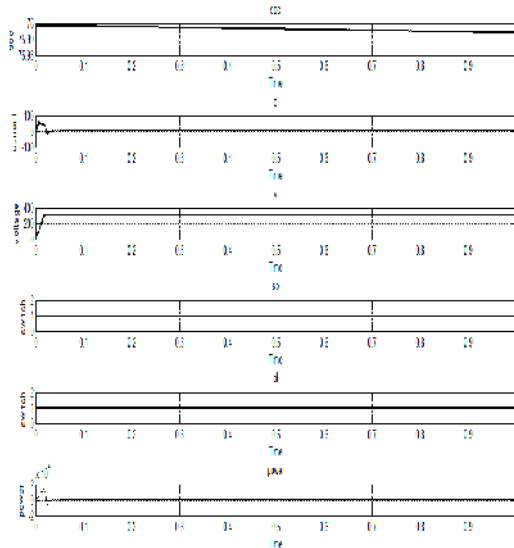

**Fig. 6.** Simulation Results of battery.

Scope2 shows the results of super capacitor with state of charge (soc), voltage, super capacitor current ,connection between source and super capacitor,

connection between super capacitor and load, power supplied by the super capacitor.

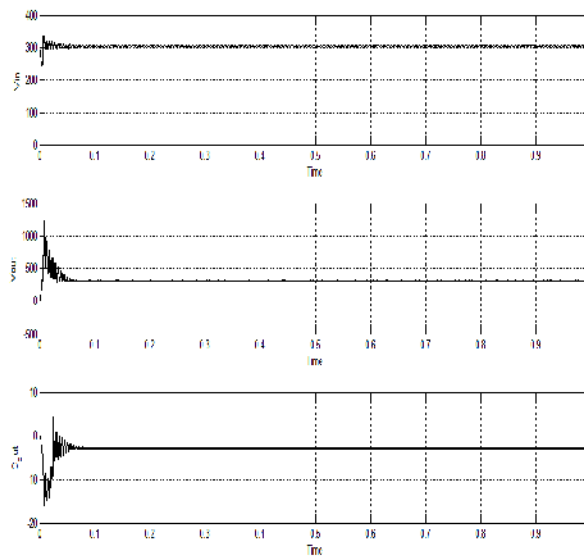

Fig. 7. Simulation results of DC-DC converter.

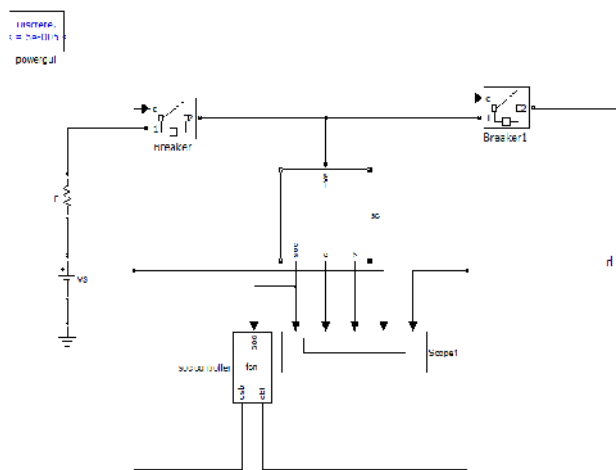
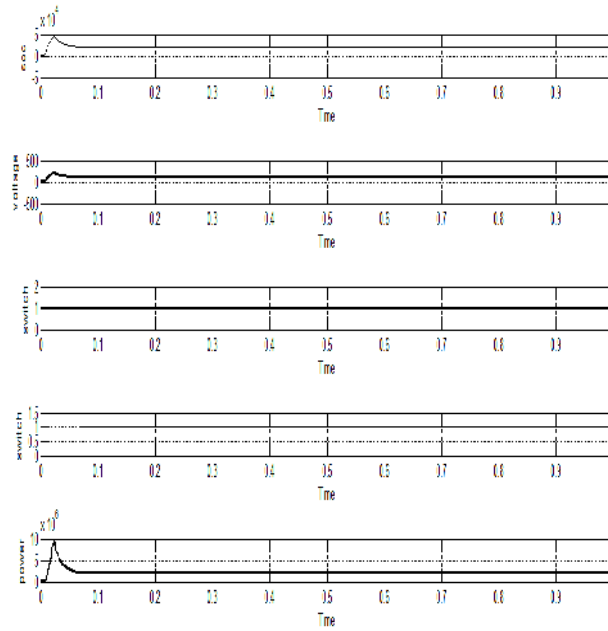
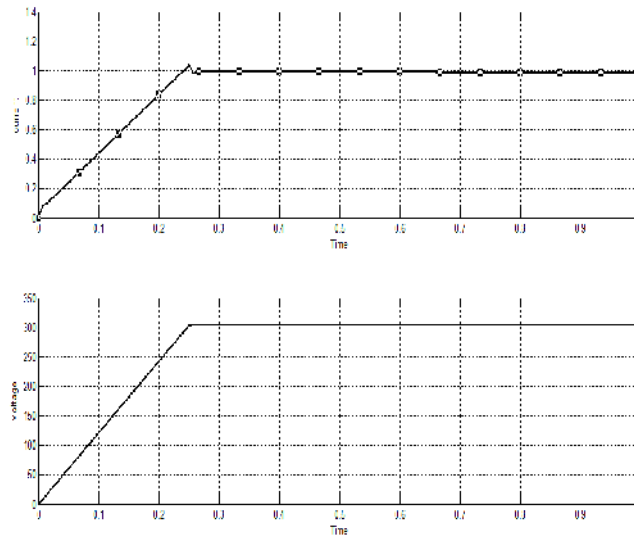

Fig. 8. Simulation diagram of supercapacitor.



**Fig. 9.** Simulation results of super capacitor.



**Fig. 10.** Simulation results of fuel cell stack.

**IV. CONCLUSION**

From the simulation and analysis of battery and supercapacitor hybrid energy storage system it is concluded that, it gives better overall performance, improved efficiency. It is highly efficient and reliable. The paper presents the benefits of hybridization of an

energy storage for an urban electric vehicle. Simulation results show how combination of lithium batteries and ultracapacitors improves the efficiency and reliability of the source. The hybridized source can provide desired maximal power independently to battery ageing process, in various temperature conditions.

Energy recovered during regenerative braking is stored firstly in ultra capacitors, which makes this process more efficient than in case of storing it in an electrochemical battery. At the same time hybridization reduces the maximum battery current and number of executed cycles, slowing down battery ageing process and extending time periods between maintenance (costly battery replacement operations).

## V. FUTURE SCOPE

- 1) Hybrid electrical energy storage (HEES) system is one of the most promising and practical ways to achieve a high performance and low-cost EES system.
- 2) we can propose an effective way of solving the ICA problem and getting near-optimal solution.
- 3) Introduction of microcontroller gives more efficient result.

## REFERENCES

- [1]. Rahul Karangia, Mehulsinh Jadeja ,Chetankumar Upadhyay, Dr. Hina Chandwani "Battery-Supercapacitor Hybrid Energy Storage System Used in Electric Vehicle", *Energy Efficient Automotive Technologies IEEE Transactions* , July 2013.
- [2]. Jian Cao & Ali Emadi, "A New Battery / Supercapacitor Hybrid Energy Storage System for Electric, Hybrid, and Plug-In Hybrid EVs," *IEEE Transactions On Power Electronics*, VOL. **27**, NO. 1, JANUARY 2012.
- [3]. Alireza Khaligh, Zhihao Li, "Battery, Supercapacitor, Fuel Cell, and Hybrid Energy Storage Systems for Electric, Hybrid Electric, Fuel Cell, and Plug-In Hybrid EVs: State of the Art," *IEEE Transactions On Vehicular Technology*, VOL. **59**, NO. 6, JULY 2010.
- [4]. Phatiphat Thounthong, Viboon Chunkag, Panarit Sethaku , "Comparative Study of Fuel-Cell Vehicle Hybridization with Battery or Supercapacitor Storage Device," *IEEE Transactions On Vehicular Technology*, OCTOBER 2009.
- [5]. Ying Wu, Hongwei Gao, "Optimization of Fuel Cell and Supercapacitor for Fuel-Cell EVs," *IEEE Transactions On Vehicular Technology*, VOL. **55**, NO. 6, NOVEMBER 2006.
- [6]. M. Y. Ayad, M. Becherif, S. AitCheikh and M. Wack. "The use of Supercapacitors in EV: modeling, sizing and control," *Vehicle Power and Propulsion Conference (VPPC)*, 2010 IEEE.
- [7]. Douglas and P. Pillay, "Sizing ultracapacitors for hybridelectric vehicles", *31st IEEE annual conference of industrial electronics*, May 2000, pp. 37-50.
- [8]. Z. Yicheng, L. Haiquan, X. Haitao, and W. Lulu "Analysis of the time-domain and frequency-domain models of supercapacitors," *IEEE Vehicle Power and Propulsion Conference (VPPC), Harbin, China*, September 2008, pp. 191-196
- [9]. P. F. Ribeiro, B. K. Johnson, M. L. Crow, and A. Arsoy, and Y. Liu, "Energy storage systems for advanced power applications," *Proceedings of the IEEE*, vol. **89**, issue 12, pp. 1744-1756, 2001
- [10]. T. Kinjo, T. Senjyu, N. Urasaki, and H. Fujita, "Output levelling of renewable energy by electric double layer capacitor applied for energy storage system," *IEEE Trans. Energy Convers.*, vol. **21**, no. 1, pp. 221-227, 2006
- [11]. M. Jain, M. Daniele, P. K. Jain, "A bidirectional dc-dc converter topology for low power application," *IEEE Trans. Power Electron.*, vol. **15**, no.4, pp. 595-606, 2000
- [12]. T. Kohama, M. Yamashima, and T. Nishimiya, "Operation-mode control of active-clamped bi-directional flyback converter as EDLC charger and discharger," *PCC-Osaka 2002*, vol. **3**, pp. 1155-1159, 2002
- [13]. A. D. Swingler and W. G. Dunford, "Development of a bi-directional dc/dc converter for inverter/charger applications with consideration paid to large signal operation and quasi-linear digital control," *PESC 2002*, vol. **2**, pp. 961-966, 2002
- [14]. F. Z. Peng, H. Li, G.-J. Su, and J. S. Lawler, "A new ZVS bi-directional dc-dc converter for fuel cell and battery application," *IEEE Trans. Power Electron.*, vol. **19**, no. 1, pp. 54-65, 2004
- [15]. uk, Slobodan; R.D. Middlebrook, (June 8, 1976). "A General Unified Approach to Modelling Switching-Converter Power Stages" (PDF). *Proceedings of the IEEE Power Electronics Specialists Conference*. Cleveland, OH. pp. pp.73–86. Retrieved 2008-12-31.
- [16]. Adam Marcus Namisnyk. "A Survey of Electrochemical Supercapacitor Technology" , (in German). Retrieved 2011-06-24.